

Worksheet 2-060: Fused and non-fused spurs power circuit

NB: Students must not attempt this exercise before the correct use of all tools and materials has been demonstrated.

Technical data

- You are to make sure that your work area is clear and safe for work to proceed.
- You are to make sure that all your work conforms to the requirements of the Health and Safety at Work Act.
- All practical electrical installation exercises must comply with BS 7671:2018 (IET Wiring Regulations).
- All terminations must be mechanically and electrically sound.

Material required

The following are the items of material required **IN ADDITION** to those used in the previous worksheet (Worksheet 2-050).

3 off	Surface mounted moulded socket box 1-gang
1 off	Insulated switched flush socket outlet 1-gang, 13A
1 off	Insulated switched flush fused connection unit (C/W 3A fuse)
1 off	'FAN' connection unit
2 off	Surface mounted moulded socket box 2-gang
2 off	Insulated switched flush socket outlet 2-gang, 13A
1 off	30 amp, 3-terminal insulated junction box
10 off	3.5 x 20mm raised countersunk set pins
	2.5mm ² twin and cpc PVC insulated and sheathed cable
	1.5mm ² twin and cpc PVC insulated and sheathed cable
300mm	2mm green/yellow cpc sleeving
	Clips, screws and pins, as detailed in the exercise demonstration

Procedure

1. Enter the start time on the assessment sheet.
2. Study the diagram and from it draw a wiring diagram.
3. **This diagram must be handed in for assessment before proceeding.**
4. Prepare the material requisition for the required materials.
5. **Have the requisition checked before proceeding.**
6. Obtain the material from the stores.
7. Carry out the installation.
8. Carry out the necessary tests on the installation and record all readings obtained on the assessment sheet.
9. **Notify the Lecturer that the work is ready for assessment.**
10. Enter the finish time on the assessment sheet.

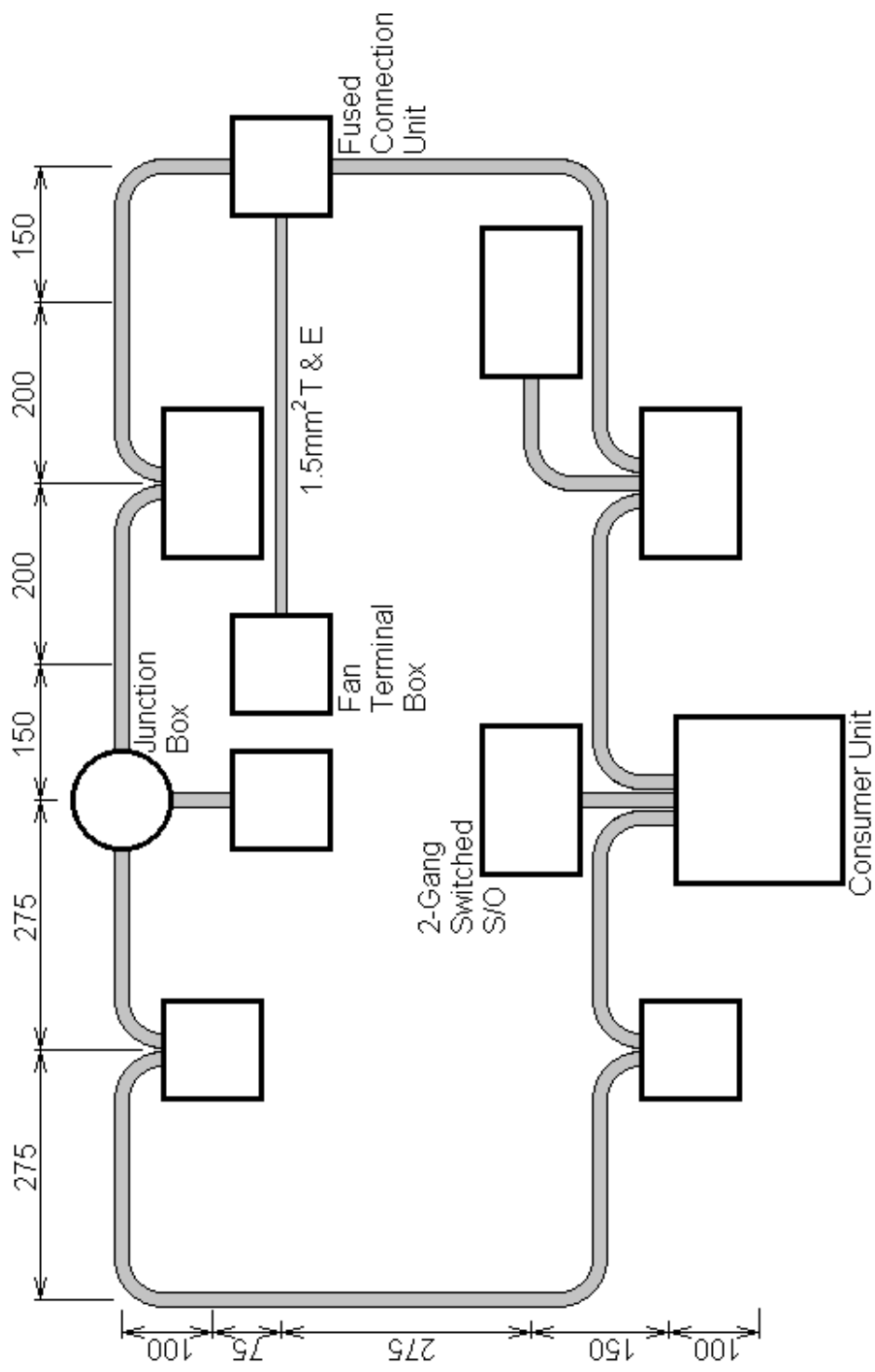

TITLE	
Fused and Non Fused Spurs Power Circuit	
Dimensions in Millimeters	Target Time 4 hrs.
Scale N.T.S.	Ex No. 2/060

Test results

cpc Continuity Test

Instrument Used:			
Instrument Serial No.:		Range Setting:	
CCU-Socket 1 Reading:			
CCU-Socket 2 Reading:			
CCU-Socket 3 Reading:			
CCU-Socket 4 Reading:			
CCU-Socket 5 Reading:			
CCU-Socket 6 Reading:			
CCU-Connection unit (FCU) Reading:			
CCU-Fan terminal Reading:			

Continuity of Ring Final Circuit Test

Instrument Used:			
Instrument Serial No.:		Range Setting:	
Line-Line Loop Reading (r_1):			
Neutral-Neutral Loop Reading (r_n):			
CPC-CPC Loop Reading (r_2):			
Line-Neutral Skt 1 Reading:			
Line-Neutral Skt 2 Reading:			
Line-Neutral Skt 3 Reading:			
Line-Neutral Skt 4 Reading:			
Line-Neutral Skt 5 Reading:			
Line-Neutral Skt 6 Reading:			
Line-Neutral Skt 7 Reading:			
Line-Neutral FCU Reading:			
Line-CPC Skt 1 Reading:			
Line-CPC Skt 2 Reading:			
Line-CPC Skt 3 Reading:			
Line-CPC Skt 4 Reading:			
Line-CPC Skt 5 Reading:			
Line-CPC Skt 6 Reading:			
Line-CPC Skt 7 Reading:			
Line-CPC FCU Reading::			

Insulation Resistance Test

Instrument Used:			
Instrument Serial No.:		Range Setting:	
Line-Neutral Reading:			
Line/Neutral-Earth Reading:			

Polarity Test

Instrument Used:		
Socket 1 Polarity:		
Socket 2 Polarity:		
Socket 3 Polarity:		
Socket 4 Polarity:		
Socket 5 Polarity:		
Socket 6 Polarity:		
Socket 7 Polarity:		
FCU Polarity:		
Fan terminal Polarity:		

Assessments are based on **observed** safety procedures, and the **quality** and **accuracy** of the completed exercise.

		YES	NO
1.	Wiring diagram function correct	<input type="checkbox"/>	<input type="checkbox"/>
2.	Wiring diagram drawn neatly	<input type="checkbox"/>	<input type="checkbox"/>
3.	Wiring diagram drawn using correct symbols	<input type="checkbox"/>	<input type="checkbox"/>
4.	Wiring diagram labelled correctly	<input type="checkbox"/>	<input type="checkbox"/>
	Assessed by:		
5.	Material requisition correct first time	<input type="checkbox"/>	<input type="checkbox"/>
6.	Method statement completed	<input type="checkbox"/>	<input type="checkbox"/>
	Assessed by:		
7.	Inspection and testing completed correctly	<input type="checkbox"/>	<input type="checkbox"/>
8.	Test results correctly recorded	<input type="checkbox"/>	<input type="checkbox"/>
9.	Accessories fixed in correct positions	<input type="checkbox"/>	<input type="checkbox"/>
10.	Accessory covers all fixed securely	<input type="checkbox"/>	<input type="checkbox"/>
11.	Correct sized cable used	<input type="checkbox"/>	<input type="checkbox"/>
12.	Cable sheath taken into all accessories	<input type="checkbox"/>	<input type="checkbox"/>
13.	Clip position/spacings acceptable	<input type="checkbox"/>	<input type="checkbox"/>
14.	Bends formed correctly (minimum radii and uniform)	<input type="checkbox"/>	<input type="checkbox"/>
15.	Circuit functions correctly	<input type="checkbox"/>	<input type="checkbox"/>
16.	Consumer unit correctly connected	<input type="checkbox"/>	<input type="checkbox"/>
17.	Consumer unit correct size protective device	<input type="checkbox"/>	<input type="checkbox"/>
18.	cpc sheathed correctly	<input type="checkbox"/>	<input type="checkbox"/>
19.	Conductors connected to correct terminations	<input type="checkbox"/>	<input type="checkbox"/>
20.	Suitable amount of spare cable left in accessories	<input type="checkbox"/>	<input type="checkbox"/>
21.	Conductor insulation undamaged at terminations	<input type="checkbox"/>	<input type="checkbox"/>
22.	Conductors doubled as appropriate and secure	<input type="checkbox"/>	<input type="checkbox"/>
23.	Sheath/insulation stripped to correct position	<input type="checkbox"/>	<input type="checkbox"/>
24.	Conductors undamaged at terminations	<input type="checkbox"/>	<input type="checkbox"/>
25.	Overall appearance to a commercially acceptable standard	<input type="checkbox"/>	<input type="checkbox"/>
26.	Work area conformed to requirements of HASAWA	<input type="checkbox"/>	<input type="checkbox"/>
27.	Correct safety procedures observed at all times	<input type="checkbox"/>	<input type="checkbox"/>
	Assessed by:		

Start Date & Time: Finish Date & Time:
 Target Time: 4 hours Time Taken:
